

# PA HIGH SPEED COMPACT HOLLOW ROTARY HYDRAULIC CYLINDERS

## 超薄型高速中空油壓迴轉缸

新產品  
**NEW**



### 尺寸圖 » Dimensions

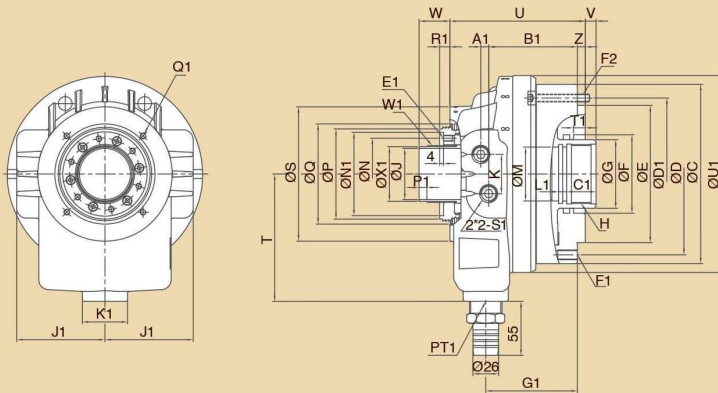

### 規格表 » Specifications

單位/UNIT:mm

型式/規格 MODEL /SPEC.	A1	B1	C	C1	D	D1	E (h7)	E1	F	F1	F2	G	G1	H	J	
PA1246	8	80.5	165	25	147	147	130	6-M6x1P	75	12-M10x1.5P	6-M8x1.25P	65	86	M55x2P	46	
PA1452	8	90	183	30	165	165	140	6-M6x1P	80	6-M10x1.5P	6-M8x1.25P	70	93.5	M60x2P	52	
PA1775	10.5	109.9	215	35	195	195	160	6-M6x1P	105	12-M10x1.5P	6-M10x1.5P	95	111	M85x2P	75	
型式/規格 MODEL /SPEC.	J1	K	K1	L1	M	N	N1	P	P1	Q	Q1	R1	S	S1	T	T1
PA1246	80	40	46	15	50	64	76	85	9	90	4-M5x0.8P(PCDø98)	10.5	121	PT 3/8	120	12
PA1452	90	40	46	15	55	73	85	96	8	102	4-M6x1P(PCDø110)	10.5	137	PT 3/8	130	12
PA1775	106	46	46	15	80	98	108	120	9	126	4-M6x1P(PCDø155)	10.5	165	PT 1/2	160	12
型式/規格 MODEL /SPEC.	U	U1	V max.	V min.	W max.	W1	W min.	X1	Z	活塞行程 Piston Stroke (mm)	最高迴轉速 Max.Speed r.p.m.(min <sup>-1</sup> )	活塞直徑 Piston Dia (mm)				
PA1246	120	183	5	-11	45	M52x1.5P	29	49.8	8	16	8000	128				
PA1452	138	201	11	-11	53.5	M58x1.5P	31.5	55.8	8	22	6500	145				
PA1775	165	233	14	-11	57	M84x2P	32	80.8	8	25	5500	170				
型式/規格 MODEL /SPEC.	慣性矩I Moment of Inertia (kg·m <sup>2</sup> )	流量 Oil Leakage Rate (l/min)	最高使用壓力 Max. Pressure kgf/cm <sup>2</sup> (Mpa)	活塞面積 Piston Area (cm <sup>2</sup> )	最大推(拉)力 Max. Operating Force											
				推力側 Push Side	拉力側 Pull Side	推力側Push Side kgf (KN)	拉力側Pull Side kgf (KN)									
PA1246	0.02	3.0	46 (4.5)	103.5	92	4250 (41.6)	3800 (37.5)									
PA1452	0.035	3.9	46 (4.5)	134	123	5500 (53.9)	5100 (50)									
PA1775	0.065	4.2	46 (4.5)	165	151	6800 (66.7)	6300 (61.8)									

\*流量測試標準-壓力:30kgf/cm<sup>2</sup>(2.94Mpa) 油溫:50°C \*Test standard of oil leakage: Pressure-30 kgf/cm<sup>2</sup>(2.94Mpa), Oil temperature-50°C