

# CT 3-JAW ADJUSTMENT STEEL BODY SCROLL CHUCKS

## 可調式普通型三爪鋼殼夾頭

### 尺寸圖 » Dimensions

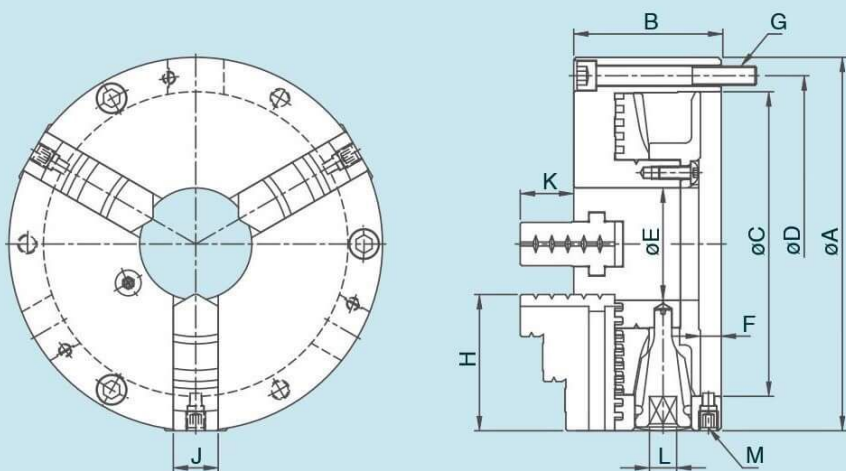

### 規格表 » Specifications

單位/UNIT:mm

型式/規格 MODEL /SPEC.	A	B	C	D	E	F	G	H	J	K	L	M	最高迴轉速 Max.Speed r.p.m.(min <sup>-1</sup> )	把握範圍 Max. Gripping Diameter		淨重 Weight (kg)
														外徑把握 O.D.Clamping	內徑把握 I.D.Clamping	
CT-06	167	75.5	130	147	45	12	3-M10x1.5P	65	22	28	10	3-M12x1.75P	4000	ø4~ø160	ø48~ø150	10.4
CT-07	193	85	155	172	58	12	3-M10x1.5P	75	24	28.5	11	3-M12x1.75P	3500	ø4~ø180	ø56~ø170	12.9
CT-09	233	92	190	210	70	12.5	3-M12x1.75P	85	28	33	12	3-M12x1.75P	2900	ø5~ø220	ø62~ø210	20.4
CT-10	275	98	230	250	89	12.5	3-M12x1.75P	98	30	38	12	3-M12x1.75P	2500	ø6~ø260	ø70~ø250	29.3
CT-12	310	111	260	285	105	14	3-M12x1.75P	110	32	45	14	3-M12x1.75P	2200	ø10~ø300	ø86~ø290	43.7