

HC40-1

大型中實油壓夾頭生爪

Soft jaw for hydraulic power chuck

重量 Weight
17 kg / PC

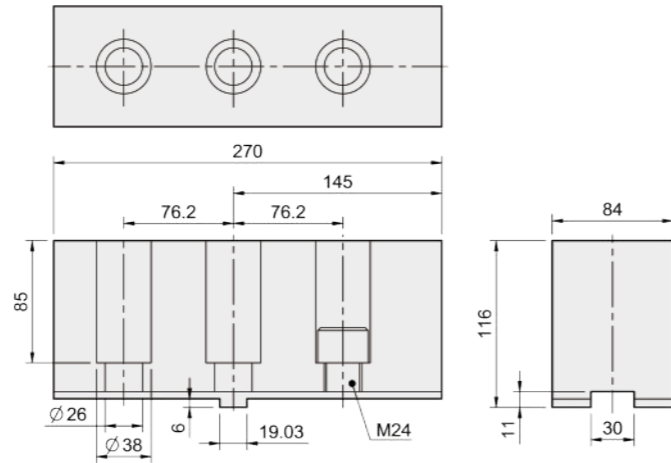

HJ40-1

大型中實油壓夾頭硬爪

Hard jaw for hydraulic power chuck

重量 Weight
11 kg / PC

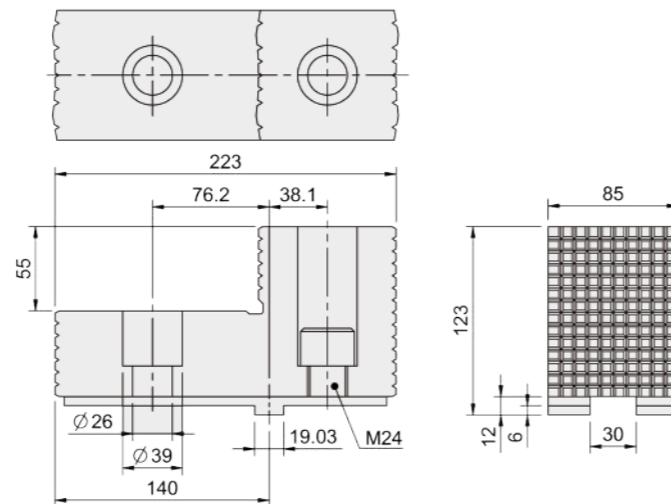

HJ

油壓夾頭硬爪

Hard jaw for hydraulic power chuck

1. 油壓夾頭用硬爪。
2. CNC車床用硬爪。



Fig-1

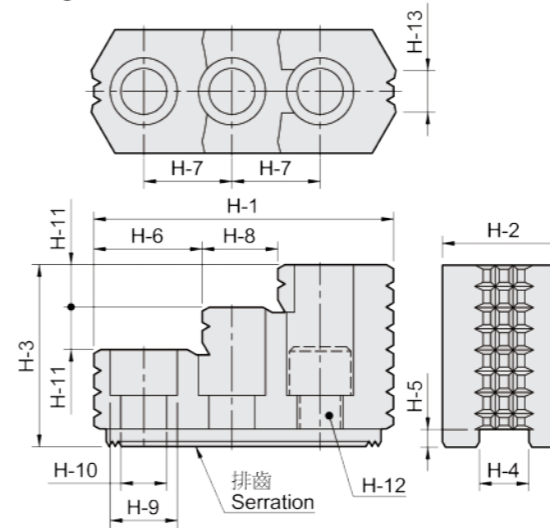
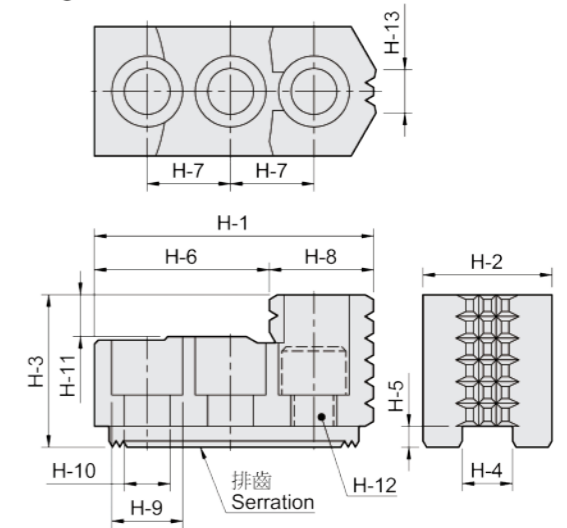

Fig-2



單位 : mm

型式規格	H-1	H-2	H-3	H-4	H-5	H-6	H-7	H-8	H-9	H-10	H-11	H-12	H-13	排齒節距	參考圖	適合夾頭	三爪重量 (kg)
HJ05	53	23	27.5	10	4	30.5	14	22.5	13.5	8.5	10	M8	6	1.5x60°	Fig-2	N-204, N-205, V-205	0.4
HJ06	67	31	35	12	5	39.5	20	27.5	17	11	12	M10	11	1.5x60°	Fig-2	N-206, NL-06, V-206	1.0
HJ08	86	35	51	14	5	31	25	18	19	13	12	M12	12	1.5x60°	Fig-1	N-208, NL-08, V-208	1.9
HJ10	99.5	40	54	16	5	43	30	17	19	13	13	M12	15	1.5x60°	Fig-1	N-210, NL-10, V-210	2.9
HJ12	103	50	52	21	4	62.5	30	40.5	25	17	17	M16	30	1.5x60°	Fig-2	N-212	3.5
HJ12-1	103	50	52	18	5	62.5	30	40.5	22	15	17	M14	30	1.5x60°	Fig-2	V-212	3.6
HJ15	149	62	86	22	8	63	43	34	32	21	20	M20	40	1.5x60°	Fig-1	N-215, N-218	9.6
HJ15-1	149	62	86	25.5	5	63	43	34	32	21	20	M20	40	1.5x60°	Fig-1	V-215, V-218	9.5
HJ24-1	159.5	80	90	25	9	104.5	50	55	32	21	40	M20	55	3.0x60°	Fig-2	N-220, N-224, N-232, V-221, V-224, V-232	14.3
PB600	140	60	75	25.5	6	50.35	38	49.86	31	21	19	M20	21.1	3/32"x90°	Fig-1	PB-ES600	7.2
PB850	220	75	85	30	6.5	130	62	90	38	26	30	M25	35	3/32"x90°	Fig-2	PB-ES850	20.2