

鎢鋼固定頂針

SOLID CENTERS OF CARBIDE TIPPED (AA CLASS)

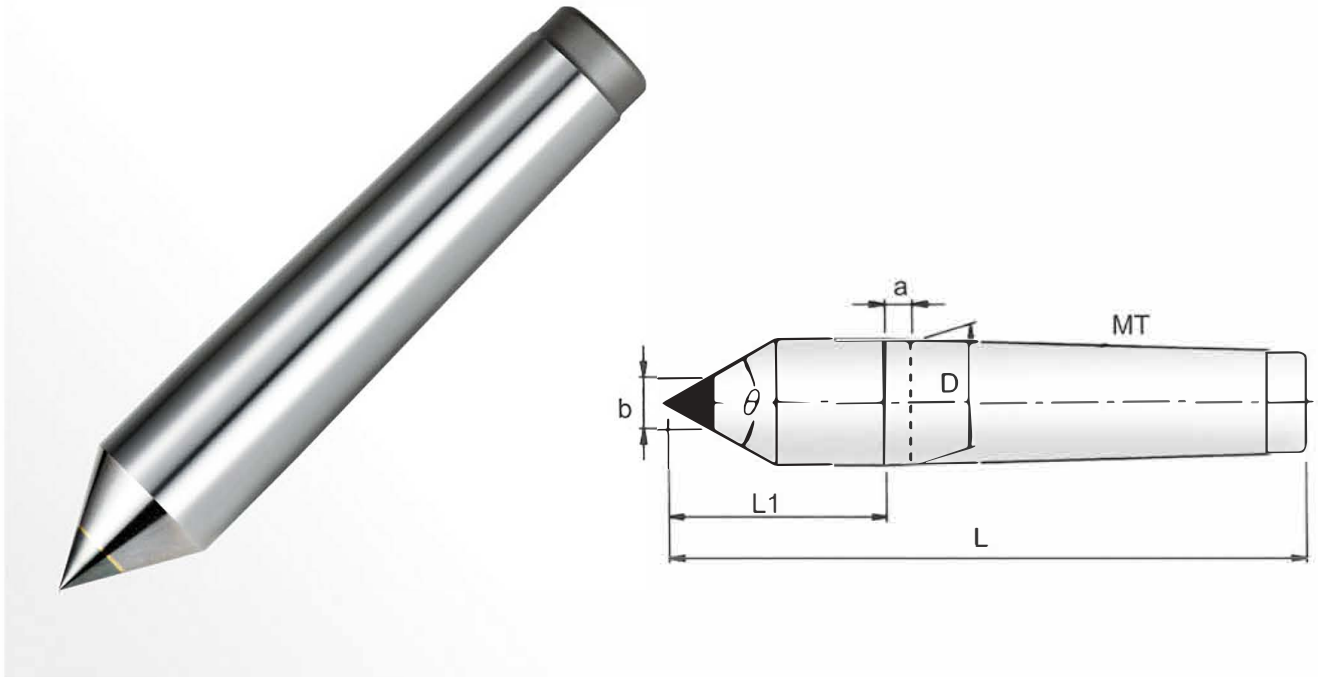

1. 本體使用高碳鋼之材質；經熱處理。
2. 本體及頂心經過精密研磨處理。
3. 適用於車床及磨床等機械。
4. 外徑斜度(Morse Taper)採用DIN806規格。

1. Body is made of carbon tool steel with heat treatment.
2. Body and Center is under precise grinding process.
3. Application to lathe and grinder.
4. Morse Taper complies with DIN806 standard.

單位/Unit:mm

產品規格 MODEL No.	D	a	b	L1	L	Co.精度 Accuracy	θ
MT3C10	23.825	5	10	39	125	0.005	60°
MT4C14	31.267	6.5	14	46	155	0.005	60°
MT5C18	44.399	6.5	18	64	200	0.005	60°
MT6C30 (訂製品)	63.348	8	30	80	270	0.005	60°